

# SETHCO

## OPERATING INSTRUCTIONS



### ZDX 1/3ES

700 Emlen Way • Telford, PA 18969  
Phone: 215.723.8155

# Sethco

## INDEX

<b>Sethco Warranty</b> .....	2	<b>Operating Instructions (cont.)</b>	
<b>Safety Rules</b> .....	3	Inspection.....	5
<b>Operating Instructions</b> .....	4	Reassembly.....	5
General Description.....	4	Troubleshooting.....	6
Pre-installation.....	4	No Discharge.....	6
Pump Installation.....	4	Insufficient Discharge.....	6
Piping the Pump.....	4	Insufficient Pressure.....	6
Discharge Piping.....	4	Excess Power Consumption.....	6
Suction Piping.....	4	<b>Operational Start-up Checklist</b> .....	7
Electrical Connections.....	5	<b>ZDX 1/3ES Assembly Drawing</b> .....	8
Rotation.....	5	<b>ZDX 1/3ES Outline Drawing</b> .....	9
Starting.....	5	<b>ZDX 1/3ES Curves (3500 RPM)</b> .....	10
Operational Checklist.....	5	<b>ZDX 1/3ES Wiring Diagrams</b> .....	11
Disassembly.....	5	<b>Notes</b> .....	12

### ORDERING REPLACEMENT PARTS

For future reference fill in the following information from the pump nameplate. This will be necessary to ensure accuracy when ordering replacement parts.

Model \_\_\_\_\_

Size \_\_\_\_\_

Serial Number \_\_\_\_\_

Material of Construction \_\_\_\_\_

700 Emlen Way • Telford, PA 18969  
Phone: 215.723.8155

# Sethco

## SETHCO WARRANTY

### WARRANTY

SETHCO pumps are warranted by the Company, insofar as the same are of its own manufacture, against defects in materials and workmanship under proper and normal use and service, for a period of one year from the date of original shipment from the factory. SETHCO's obligation is limited, however, to furnishing without charge, F.O.B. its factory, new parts to replace any similar parts of its own manufacture so proving defective within said period, provided the Buyer has given SETHCO immediate written notice upon discovery of such defect. No allowance will be made for labor charges. SETHCO shall have the option of requiring the return of the defective material, transportation prepaid, to establish the claim.

SETHCO makes no warranty or guarantee whatsoever, either express or implied, of prime mover, starting equipment, electrical apparatus, parts or material not manufactured by SETHCO, except to the extent that warranty is made by the manufacturer of such equipment and material.

SETHCO assumes no liability for damages or delays caused by defective material, and no allowance will be made for local repair bills or expenses without the prior written approval or authority of SETHCO.

Under no circumstances will SETHCO be liable for indirect, special or consequential loss or damage of any kind and the Buyer assumes all liability for the consequences of its use or misuse by the Buyer, his employees, or others.

### PERFORMANCE GUARANTEE

Is at the specified point of rating only and will not cover performance under conditions varying therefrom, nor for sustained performance over any period of time.

### ACCEPTANCE TESTS

If required, shall be conducted in accordance with the practices as set forth in the Hydraulic Institute Standards. The expense of any such tests shall be borne by the Buyer.

### PERFORMANCE PRESENTATIONS

Are based on shop laboratory tests with cold water as outlined in the Hydraulic Institute Standards.

### FIELD TESTING

Due to the inaccuracies of field testing, the results of any such tests conducted by or for the Buyer shall be interpreted as being only indicative of the actual field performance of the pump. No equipment will be furnished on the basis of acceptance by results of field tests. If the Buyer, after such a test, questions the performance of the pump, he may at his option request a test to establish the performance. Such tests will be conducted in accordance with the above paragraph entitled "Acceptance Tests."

### ALL WARRANTIES

Are void if -

- a. Pipe strains are the cause of damage.
- b. Pump handles liquids other than those specified in detail.
- c. NPSH lower than required by pump impeller.
- d. Operating speed is higher than specified.
- e. Improper field installation.

To combat corrosion, abrasion, erosion, or pumping solids, foreign objects, or pumping liquids at elevated temperature, any such recommendations will be based on the best available experience of SETHCO and the supplier of the material and industry, BUT WILL NOT CONSTITUTE A GUARANTEE AGAINST THESE EFFECTS.

### RECOMMENDATIONS FOR SPECIAL MATERIALS

The foregoing warranty is made in lieu of all other warranties guarantees, obligations or liabilities, expressed or implied, by SETHCO or its representatives. All statutory or implied warranties, other than of title, are hereby expressly negated and excluded.

All illustrations and provisions in specifications are descriptive and are not intended as warranties. Penalty of any kind are not acceptable unless approved in writing by an officer of Met-Pro Corporation.

700 Emlen Way • Telford, PA 18969  
Phone: 215.723.8155

# Sethco

## SAFETY RULES FOR SETHCO VERTICAL PUMP MODEL ZDX

**Congratulations: You have just purchased a SETHCO PUMP, a quality industrial product manufactured to exacting standards.**

Thank you for choosing a SETHCO product. We look forward to serving your future requirements for quality industrial corrosion resistant pumps and filter supplies.

To insure prolonged life of your purchase, please take time to review and understand completely the operating instructions and become familiar with the pump before installing, filling, operating or maintaining this equipment.

**INSTALLATION – OPERATION – MAINTENANCE** of this equipment must be performed by trained and qualified personnel in strict accordance with the operating instructions and all applicable drawings, specifications and codes.

Obtain, read and understand the MSDS (Material Safety Data Sheet) for the liquid being handled before installing, filling, operating or maintaining this equipment.

Obtain instructions from the Safety Engineer responsible for your facility before installing, filling, operating or maintaining this equipment and connected systems.

The equipment as received has been chosen for a certain application or service. **DO NOT USE** for any other application unless written permission is obtained from the SETHCO factory. Consult the SETHCO factory with all of the service requirements so that we can assist you in a successful reapplication.

Always wear appropriate protective apparel when working on or around the pumping equipment. Gloves, aprons, footwear, faceshield and/or breathing apparatus and any other protective gear as needed for protection or as required by facility or operating procedures.

All unauthorized personnel should be kept a safe distance from any and all work areas.

Keep hands, fingers, or tools from contacting the impeller during operation of the pump and system. Disconnect, lock and tag out the main power source to prevent accidental start up.

Always keep face away from openings in the pump equipment. **DO NOT** look into hose, pump discharge or suction connections.

All auxiliary equipment such as hoses must be suitable for the chemical to be transferred. They must also be selected to safely contain the system pressure at the operating temperature. All hose clamps must be of a material that will not be attacked by corrosive environment or splashing of pumped liquid.

All connections should be checked for a secure liquid tight fit prior to filling and/or operating pump equipment or system.

Never turn pump on unless discharge and suction valves are open.

When connecting or wiring motor, follow all applicable electrical and safety codes.

Protect the power cable (when applicable) from sharp objects. **DO NOT** crimp or bind the power cable and never allow the cable to come in contact with water, oil, grease, hot surfaces, or chemicals.

Disconnect, lock and tag out the main power source to the motor before handling the pump/motor for any reason. Lock and tag out the switching device to prevent the unexpected application of power. **FAILURE COULD RESULT IN SEVERE INJURY OR DEATH.**

Avoid touching the exterior surface of the motor. It may be hot enough to be painful or cause injury.

Isolate the pump by closing suction and discharge valves prior to any maintenance. Lock and tag out the valves to prevent accidental opening.

Do not attempt to perform any maintenance on the pump/motor unit until you are confident that the pump and its contents have been neutralized and stabilized at ambient temperature and atmospheric pressure. **FAILURE COULD RESULT IN SEVERE INJURY OR DEATH.**

700 Emlen Way • Telford, PA 18969  
Phone: 215.723.8155

# Sethco

## OPERATING INSTRUCTIONS FOR SETHCO ZDX VERTICAL PUMPS

### GENERAL DESCRIPTION

Sethco close coupled vertical pumps are centrifugal type pumping units designed for installation inside or outside of an open tank. All pump parts in contact with the fluid are CPVC.

### PRE-INSTALLATION

**All Sethco pumps are tested at the factory for proper operation. Before installing your new Sethco pump, the following is recommended:**

- Determine that the equipment checks against the packing slip for completeness of order. If there is a discrepancy, please notify Sethco immediately.
- Inspect pump and any accessories packed with the unit to assure no damage has occurred during transit.
- Determine if any packing materials are lodged in the pump.
- Turn the impeller to determine that it is not bound. Damage to the drive motor can result from an excessive load.

### PUMP INSTALLATION

**WARNING: WHEN HANDLING THE PUMP UNIT, IT IS VERY IMPORTANT TO PICK UP THE UNIT BY THE MOTOR AND OR MOUNTING PANEL ONLY.**

- Your vertical pump is designed for mounting inside or outside the tank by means of the mounting panel.
- Examine mounting location for maintenance accessibility.
- Secure the unit by bolting or clamping the mounting panel in place.
- The pump shaft must be vertical to avoid damage during operation.

### PIPING THE PUMP

The pump has been designed with all necessary strength factors for a long, reliable service life. However, due to thermoplastic construction, care must be taken during installation to avoid unnecessary pipe strain. If piping strains are to be encountered, flexible connections are recommended.

- All piping must be supported independent of the pump.
- The piping should always line up naturally. Never draw the pipe to the suction or discharge connections. Piping loads transferred to the pump body assembly can cause damage to the pump.
- Outside installations should be compensated for changes in ambient temperature. Refer to pipe manufacturers standards for proper installation. Omission of this can result in severe strain transmitted to the pump body assembly.
- If expansion joints are used, they should be installed in a location to prevent loading of the pump connections.
- Piping should be as short and direct as possible. Avoid all unnecessary elbows, bends and fittings, as they increase friction losses in the piping.

### DISCHARGE PIPING

Installation of a valve in the discharge line, that can be used as a flow shutoff for inspection and maintenance, is recommended. It should be of a design to allow throttling or flow control. The diameter of the discharge valve should be as large or larger than the pump discharge.

### SUCTION PIPING

When the unit is mounted outside the tank, the pump inlet should be kept as short as possible, with minimum restrictions, for easy priming and proper operation. Inlet piping should be at least as large as the pump inlet.

700 Emlen Way • Telford, PA 18969  
Phone: 215.723.8155

# Sethco

## OPERATING INSTRUCTIONS FOR SETHCO ZDX VERTICAL PUMPS

### ELECTRICAL CONNECTIONS

All electrical work to the unit should be performed by a qualified technician. All local, state and federal electrical codes should be followed.

### ROTATION

All pumps operate in a clockwise direction when facing the motor fan guard/drip shield assembly. Connect electric motor to power supply and jog motor to check rotation. If motor is operating in the wrong direction, reverse leads and recheck.

### STARTING

**WARNING: DO NOT RUN PUMP WITH A CLOSED DISCHARGE VALVE AS THE LIQUID IN THE PUMP WILL RAPIDLY INCREASE IN TEMPERATURE, CAUSING DAMAGE TO PUMP.**

Inspect the liquid level for proper submergence of the impeller. Maximum and minimum solution depths are shown on the outline drawing and apply for both internal and external tank applications.

- See operational start-up checklist, page 7.
- Open the discharge valve to approximately 25-50% flow.
- Start the motor and bring the pump up to operating speed.
- Adjust the discharge valve to desired flow rate.

### OPERATIONAL CHECKLIST

- Periodically check for excessive vibrations and motor bearing temperatures. Correct if necessary.
- Periodically check pressure and flow rates. Adjust if necessary.

### DISASSEMBLY

Ensure that the motor is shut off and lock and tag out power supply. Check that the discharge valve is shut and any liquid has drained. Disconnect wiring to motor (tag wires for rotation). Disconnect any suction or discharge piping. Carefully lift out the pump and place in a horizontal position. Drain liquid from pump as necessary. See assembly drawing on page 8.

- 1) Remove screws (1) and cover (2).
- 2) Remove plug in motor fan guard/drip shield assembly.
- 3) Insert screwdriver into motor end shaft slot to hold shaft stationary and unscrew impeller (6); standard RH thread.
- 4) Remove screws (9, 10), mounting panel (7) and body assembly (4).

### INSPECTION

- 1) Check all internal and external threads for damage or stripped threads.
- 2) Replace all O-rings.
- 3) Check all plastic parts for cracks, abrasions and distortion.
- 4) Check shaft for run out and chemical attack. Maximum run out at end of shaft < 0.010 TIR.

### REASSEMBLY

- 1) Secure body assembly (4) and mounting panel (7) to motor (8) with screws (9, 10).
- 2) Insert screwdriver into slot in end of motor shaft and thread impeller (6) onto motor shaft; standard RH thread.
- 3) Replace O-ring (3).
- 4) Secure cover (2) to body assembly (4) with screws (1).

700 Emlen Way • Telford, PA 18969  
Phone: 215.723.8155

# Sethco

## OPERATING INSTRUCTIONS FOR SETHCO ZDX VERTICAL PUMPS

### TROUBLESHOOTING

Refer to the following diagnostic section if hydraulic problems are encountered in the pump operation.

#### NO DISCHARGE

- Pump not primed
- Speed too low
- System head too high
- Suction lift higher than that for which pump is designed
- Impeller or suction completely plugged
- Wrong direction of rotation
- Air leak in the suction line
- Discharge valve closed

#### INSUFFICIENT DISCHARGE

- Air leaks in suction
- Speed too low
- System head higher than anticipated
- Insufficient NPSHA
- Impeller or suction partially plugged
- Impeller damaged
- Suction opening not submerged enough
- Wrong direction of rotation

#### INSUFFICIENT PRESSURE

- Speed too low
- System head less than anticipated
- Air or gas in liquid
- Impeller damage
- Impeller diameter too small (wrong pump model selected)
- Wrong direction of rotation
- Discharge not throttled correctly

#### EXCESS POWER CONSUMPTION

- Speed too high
- System head lower than rating, liquid flowrate too high
- Specific gravity or viscosity of liquid pumped is too high
- Shaft bent
- Rotating elements bound

700 Emlen Way • Telford, PA 18969  
Phone: 215.723.8155

# Sethco

## ZDX 1/3ES OPERATIONAL START-UP CHECKLIST

- Pump mount is level and plumb.
- Mounting bolts are tight.
- Motor mounting bolts tight.
- Suction and discharge connections secure.
- Electrical connections secure and covered.
- Turn motor fan by hand, ensure that it does not bind.
- Jog motor/Check rotation. (Motor Fan)
- Discharge valve is slightly open.
- Ensure that pump is filled with liquid to the proper submergence.
- Start pump and open discharge valve to desired flow rate.
- Check for excessive vibration and motor bearing temperature.



# ZDX 1/3ES ASSEMBLY DRAWING

ITEM	PART NUMBER	DESCRIPTION	Material	QTY
1	790P03161-551	COVER SCREW	CPVC	4
2	140P0613-551	INLET COVER	CPVC	1
3	590P2233-830	ORING	VITON	1
4	060P301525-551	PUMP BODY	CPVC	1
5	760P10402-830	FUME BARRIER	VITON	1
6	431P102060-551	IMPELLER ASSEMBLY	CPVC	1
7	380P1332-580	MOUNTING PANEL	GFPOLY	1
8	CONSULT FACTORY	MOTOR	VARIABLES	1
9	790P1032106-680	SCREW, LONG	SS	2
10	790P103307-680	SCREW, SHORT	SS	4
11	990P1032-680	WASHER	SS	4

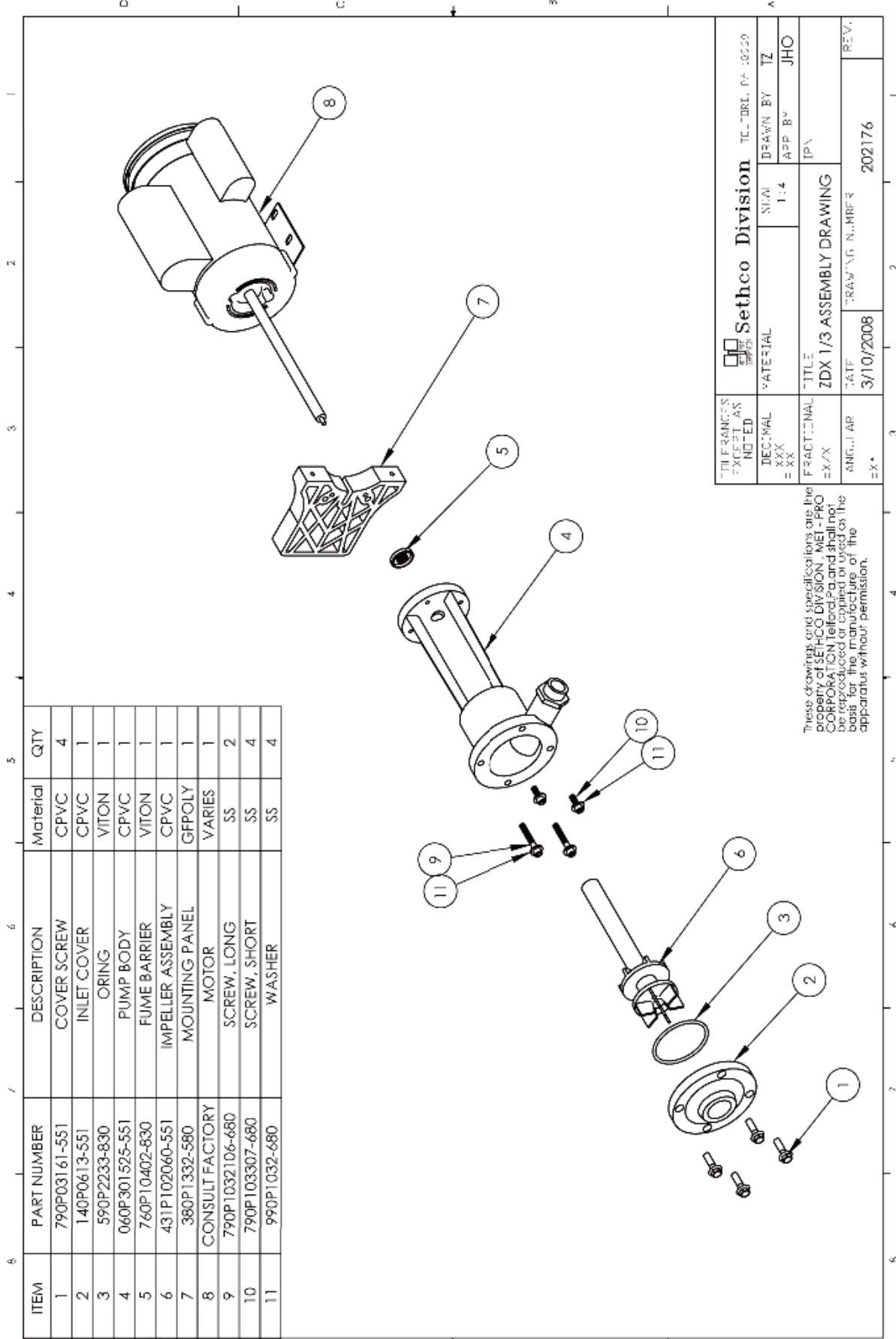

<b>Sethco Division</b>		TC. DRL. P# 30250 DRAWN BY TZ APP BY JHO
TOLERANCES UNLESS NOTED DECIMAL XXX = XX	MATERIAL SILAI 1:4	TITLE ZDX 1/3 ASSEMBLY DRAWING IP\
DATE 3/10/2008	DRAWING NUMBER 202176	REV.

These drawings and specifications are the property of SETHCO DIVISION, MET-PRO CORPORATION, Toledo, Ohio and shall not be reproduced or copied or used on the basis for the manufacture of the apparatus without permission.

# ZDX 1/3ES OUTLINE DRAWING

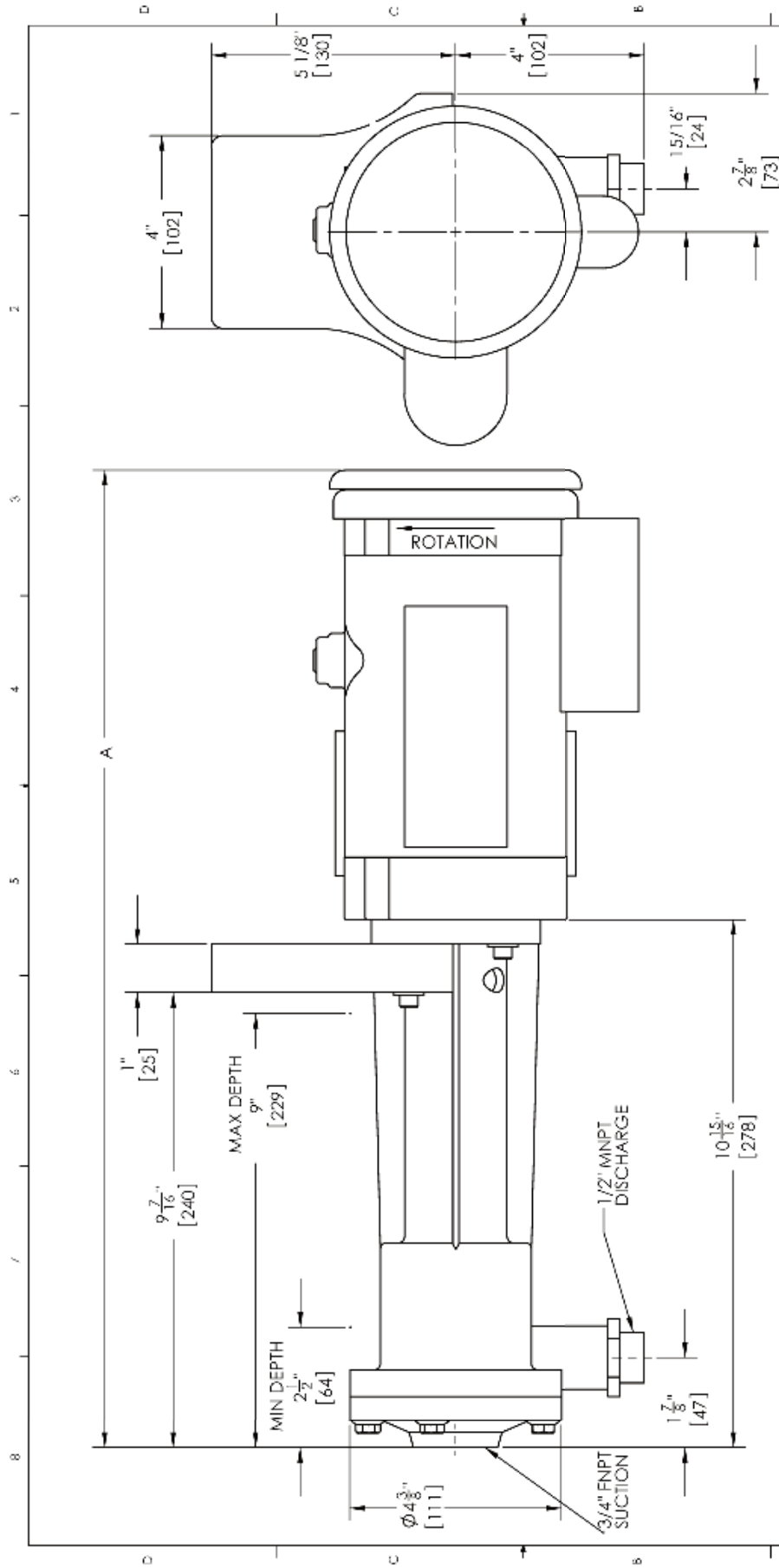

NOTE:  
 1) SINGLE PHASE 115V MOTORS SUPPLIED WITH SWITCH, CORD, AND PLUG.  
 2) SINGLE PHASE 208-230V MOTORS SUPPLIED WITH SWITCH AND CORD

MOTOR HP	VOLTAGE	A	WEIGHT (LBS/KG)
1/6	115/150-60	21 [533]	PUMP/MOTOR(DRY) 21/9.5
1/4	208-230/150-60	21 [533]	
	190/380-230/460/350-60	20 1/4 [514]	

TITLE BLOCK	DATE	APP. BY	REV
FRANKLIN	3/10/2008	JHO	202179
NOTES	DRAWING NUMBER		
1. XXXX	3/10/2008		
2. XXXX			
3. XXXX			
4. XXXX			
5. XXXX			
6. XXXX			
7. XXXX			
8. XXXX			
9. XXXX			
10. XXXX			
11. XXXX			
12. XXXX			
13. XXXX			
14. XXXX			
15. XXXX			
16. XXXX			
17. XXXX			
18. XXXX			
19. XXXX			
20. XXXX			
21. XXXX			
22. XXXX			
23. XXXX			
24. XXXX			
25. XXXX			
26. XXXX			
27. XXXX			
28. XXXX			
29. XXXX			
30. XXXX			
31. XXXX			
32. XXXX			
33. XXXX			
34. XXXX			
35. XXXX			
36. XXXX			
37. XXXX			
38. XXXX			
39. XXXX			
40. XXXX			
41. XXXX			
42. XXXX			
43. XXXX			
44. XXXX			
45. XXXX			
46. XXXX			
47. XXXX			
48. XXXX			
49. XXXX			
50. XXXX			
51. XXXX			
52. XXXX			
53. XXXX			
54. XXXX			
55. XXXX			
56. XXXX			
57. XXXX			
58. XXXX			
59. XXXX			
60. XXXX			
61. XXXX			
62. XXXX			
63. XXXX			
64. XXXX			
65. XXXX			
66. XXXX			
67. XXXX			
68. XXXX			
69. XXXX			
70. XXXX			
71. XXXX			
72. XXXX			
73. XXXX			
74. XXXX			
75. XXXX			
76. XXXX			
77. XXXX			
78. XXXX			
79. XXXX			
80. XXXX			
81. XXXX			
82. XXXX			
83. XXXX			
84. XXXX			
85. XXXX			
86. XXXX			
87. XXXX			
88. XXXX			
89. XXXX			
90. XXXX			
91. XXXX			
92. XXXX			
93. XXXX			
94. XXXX			
95. XXXX			
96. XXXX			
97. XXXX			
98. XXXX			
99. XXXX			
100. XXXX			

These drawings and specifications are the property of SETHCO DIVISION, MFC-PRO CORPORATION, Bedford, Pa. and shall not be reproduced or copied or used as the basis for the manufacture of the apparatus without permission.

SETHCO DIVISION	TITLE	SCALE	DRAWN BY
CPVC	ZDX 1/3 OUTLINE DRAWING	1:2	JHO
MATERIAL	DATE	APP. BY	REV
	3/10/2008	JHO	202179
TEL: 717.261.1000			

# ZDX 1/3ES CURVES (3500 RPM)

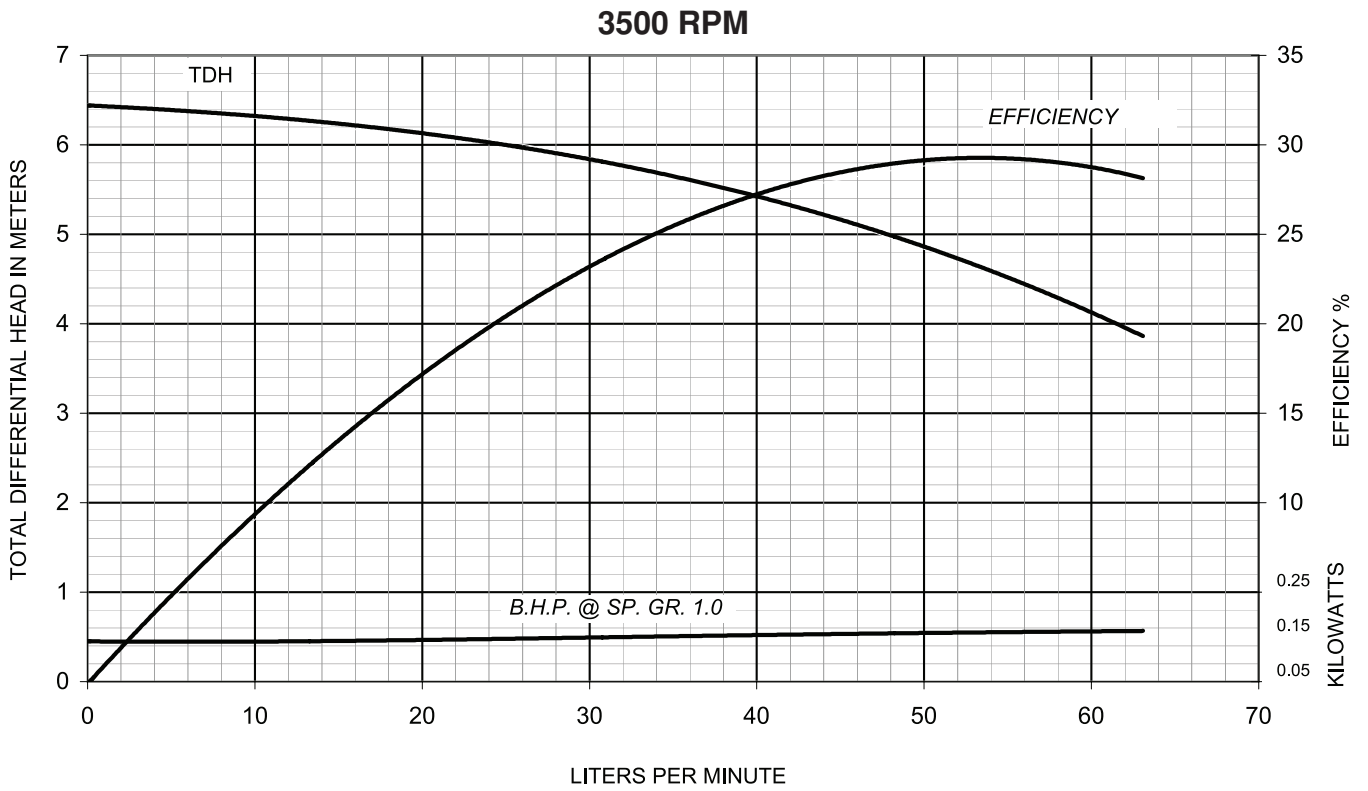
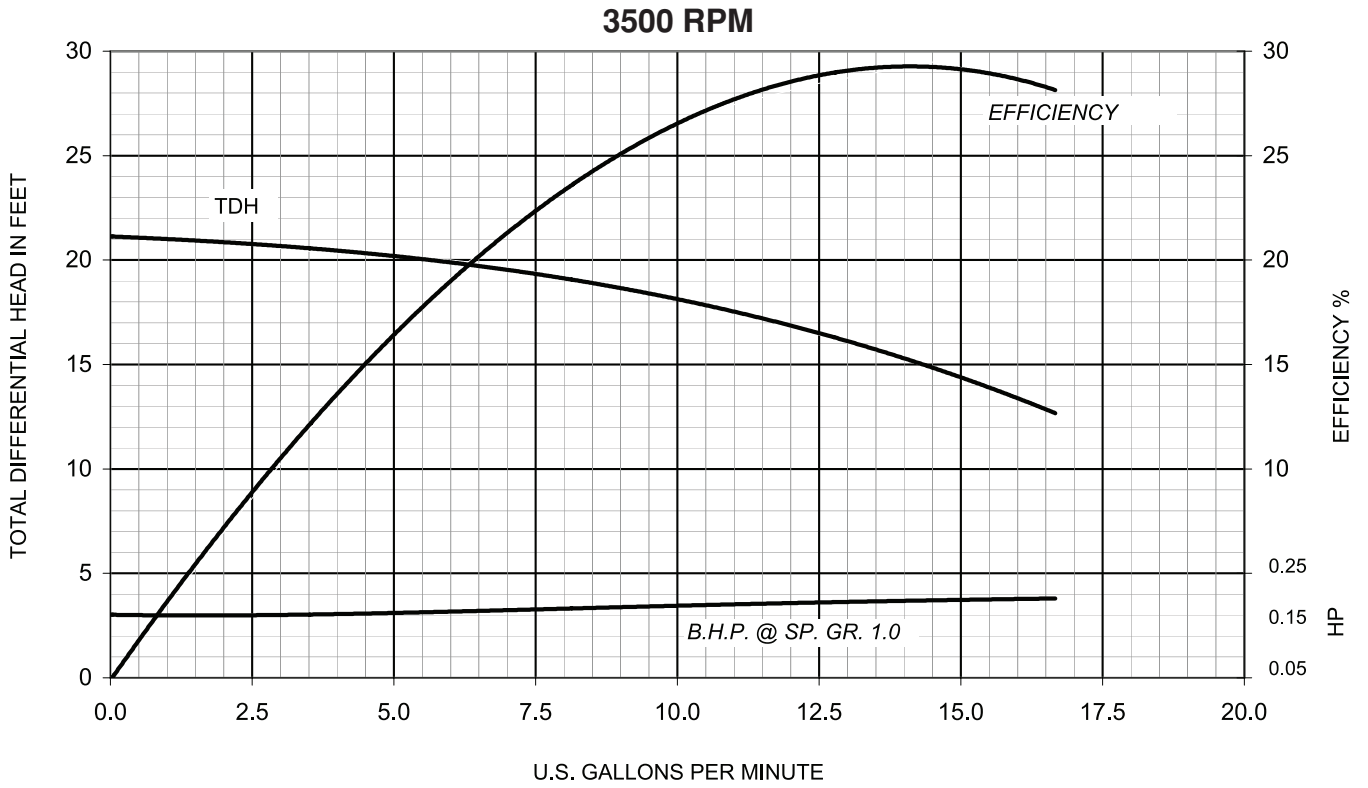

# ZDX 1/3ES WIRING DIAGRAMS

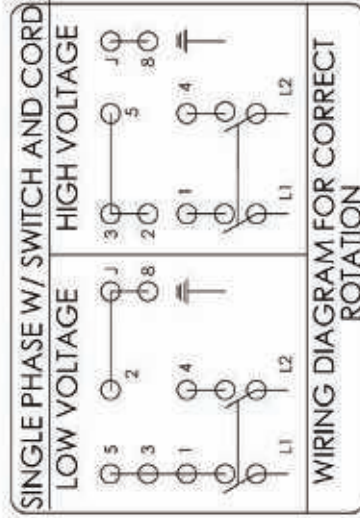
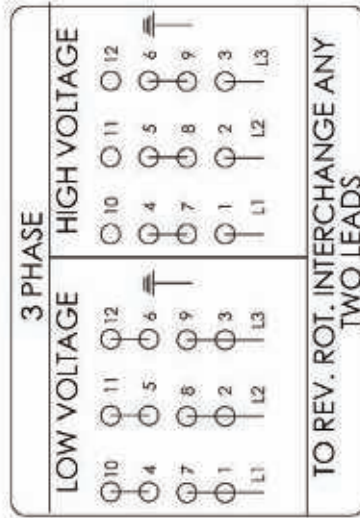

**NOTE:**  
 1) CORRECT ROTATION IS CLOCKWISE WHEN FACING THE MOTOR FAN GUARD/ DRIP SHIELD ASSEMBLY.

TOLERANCES EXCEPT AS NOTED		<b>Sethco Division</b>	TELFORD, PA 18969
DECIMAL XXX ±.XX	MATERIAL	SCALE 1:1	DRAWN BY <b>TZ</b>
FRACTIONAL ±X/X	TITLE <b>1/6 &amp; 1/4 HP WIRING DRAWING</b>		APP BY <b>JHO</b>
ANGULAR ±X°	DATE <b>2/25/2009</b>	DRAWING NUMBER <b>102586</b>	REV.

These drawings and specifications are the property of SETHCO DIVISION, MET - PRO CORPORATION, Telford, Pa. and shall not be reproduced or copied or used as the basis for the manufacture of the apparatus without permission.

## NOTES